

MC130 Linear Slide

Feature

1. Drive Mode: Ball Screw or Lead Screw
2. Max Speed: 300mm/sec Servo Motor; 30mm/sec (Step Motor)
3. Repeatability: $\pm 0.01\text{mm}$
4. Acceleration: 10m/s^2
5. Travel: 50-1520mm
6. Load Capacity: 120Kg (Max)



Part Code:

MC130 - A - 100L - 04 - P - KG5 - B0 - M1 - S0



1. Model: MC130
2. Motor installation style: A - Direct
3. Table Travel: 50mm - 1520mm
4. Screw Pitch: 4mm, 5mm, 10mm, 20mm, 25mm, 40mm, 60mm
5. Accuracy Class: P: precision C: Common
6. Load Capacity: 120Kg
7. Qty of mounting plate: 0-without mounting plate; 1-10 pcs
8. Qty of block: 1 (standard)
9. Limit Switch: S0 (without limit switch), S1, S2, S3

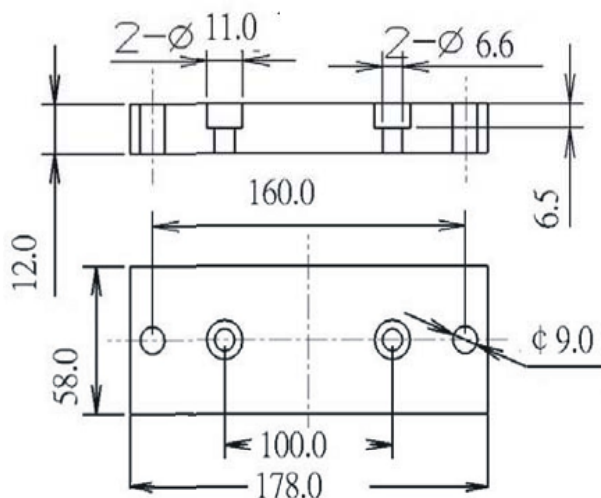
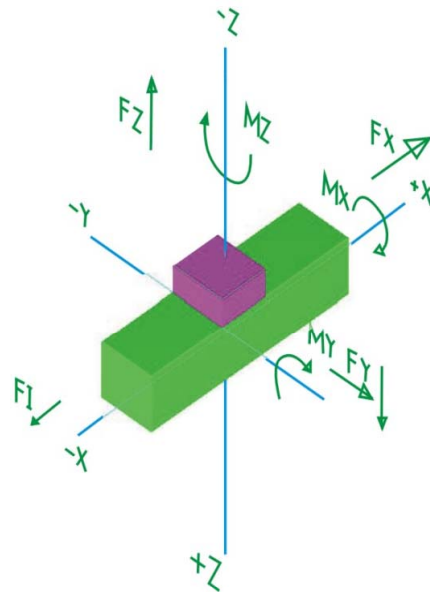

	MC130
F X	60 k g
F Y	85 k g
F Z	120 k g
M X	25 k g
M Y	25 k g
M Z	25 k g

MC-130 SERIES (BALL SCREW)

MC130A Motor Installation - Direct Installation

X-STROKE (有效行程)	200	320	440	560	800	980	1160	1340	1520
Length of L (總長)	460	580	700	820	1060	1240	1420	1600	1780

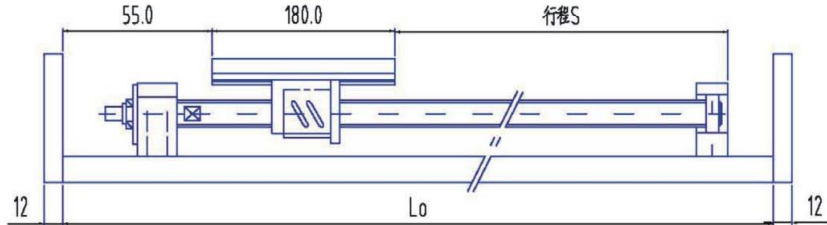
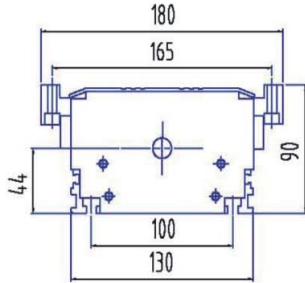

4-M8 (底部爲沉頭孔 ϕ 11-深7.5 可使用4-M6 上鎖)

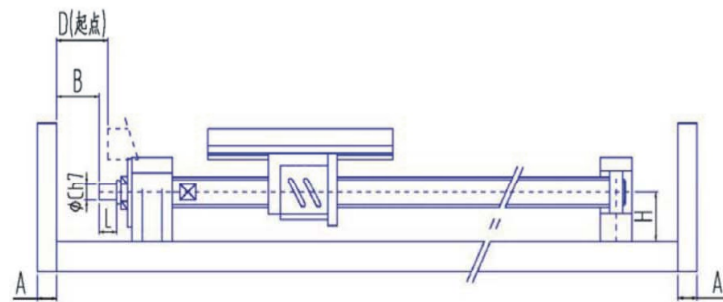
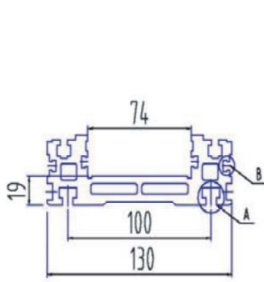
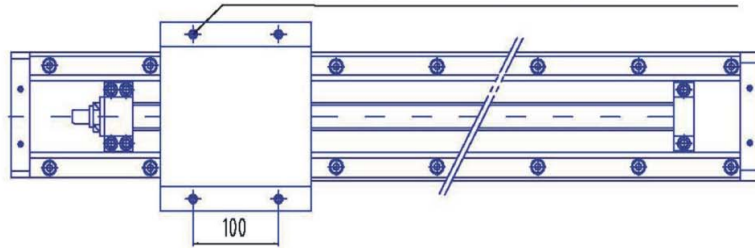

Model	A	B	C	L	D	H	W (kg/1000mm)
MC130	12	29	10	12	55	25	7.2